



Electronic Delivery Cover Sheet

WARNING CONCERNING COPYRIGHT RESTRICTIONS

The copyright law of the United States (Title 17, United States Code) governs the making of photocopies or other reproductions of copyrighted materials. Under certain conditions specified in the law, libraries and archives are authorized to furnish a photocopy or other reproduction. One of these specified conditions is that the photocopy or reproduction is not to be "used for any purpose other than private study, scholarship, or research". If a user makes a request for, or later uses, a photocopy or reproduction for purposes in excess of "fair use", that user may be liable for copyright infringement. This institution reserves the right to refuse to accept a copying order if, in its judgement, fulfillment of the order would involve violation of copyright law.

MECHANICS OF SELF-REPRODUCTION

BY L. S. PENROSE

Galton Laboratory

INTRODUCTION

The theoretical aspect of self-reproduction seems to have been first seriously considered by von Neumann (1951). Using a theorem, invented by Turing (1937), he was able to infer that the construction of an automatic machine capable of replicating itself was possible. Von Neumann thought that about twelve different kinds of units would be required as building materials but he did not specify how complicated such units would have to be. Moreover, according to Haldane (1954), it was generally believed that a very large total number of units would be needed in the actual machine, perhaps more than 10^5 .

The concept of self-reproduction needs to be defined so that any system can be tested to ascertain whether or not it agrees with the rules laid down. A structure may be said to be self-reproducing if it causes the formation of two or more new structures similar to itself in every detail of shape and also the same size, after having been placed in a suitable environment. One of the new structures may be identical with the original one. Alternatively, the original structure may be destroyed in the process of forming two new replicas. Certain conditions are added which exclude all well-known types of physical or chemical chain reactions. First, the replicating structure must be built by assembling simpler units present in the environment. Secondly, more than one design can be built from the same set of units though the only replicating structure that can be automatically assembled will be one exactly copying a previously existing structure. The pre-existing structure is known as a seed.

THE FIRST EXPERIMENTS

Apparently the first successful construction of an artificial self-reproducing object, in the strict sense defined here, was that reported by Penrose & Penrose (1957). In this model (Fig. 1), the environment contained only two kinds of solid objects which served as units. In certain restricted circumstances, two dissimilar units, A and B , could become linked together mechanically and form a structure, BA , provided that an initial structure, BA , was already present. The restricted circumstances consisted of a straight track in which the units were confined and this could be agitated horizontally. Normally, when two units collide in response to horizontal movements which they derive from the track, they rebound from one another and do not become linked. However, if the structure BA is present, any single unit colliding with this will become tilted or 'activated'. If an activated B is followed immediately by an activated A , the pair join together and form a new structure BA . Since the unit objects in this model are mechanically symmetrical, another activated structure, AB , can be formed from the same material. If AB is placed in a random collection of units, it will form new AB structures. The whole process is shown in detail in Fig. 1.

The first model can be slightly simplified so that only one asymmetrical shape is required for units; these can be turned through 180° on a vertical axis and used as partners, as shown in

Fig. 2 (i) and (ii). In a randomly assorted population, units which are facing one another, as in (i), will not normally become attached. They will link, as in (ii), if a seed of the same kind has been added to the population and the whole group set in horizontal oscillating motion.

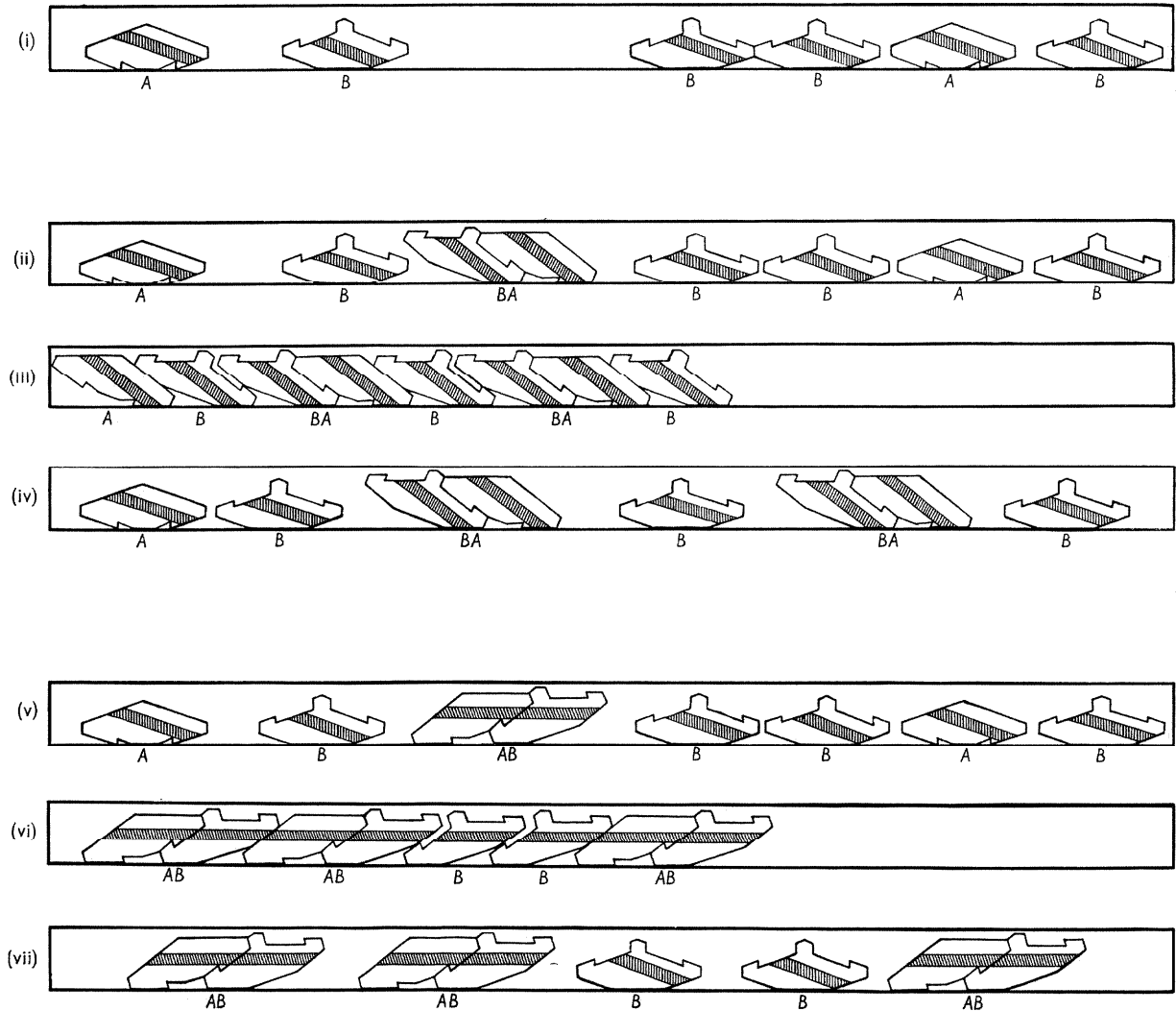

Fig. 1. Self-replicating machine made with units of two kinds. (i) Six units are shown, arranged, supposedly at random, on a track which is subject to horizontal agitation: the units do not link. (ii) Seed, BA , formed by two linked units, is introduced. (iii) Horizontal agitation now causes transmission of activation from the seed to adjacent units. (iv) As the agitation gradually ceases, the units separate but the original seed, BA , remains intact and a second linked pair has been generated. (v) The situation here is the same as in (ii) but a different seed, AB , has been introduced. (vi) A different type of activation is produced on agitation. (vii) After separation, two new pairs like AB are seen to have been generated.

It might have been thought that, to achieve mechanical self-replication, some form of magnetic or electrical forces could have been conveniently used. This was a point carefully considered and it seemed in fact much simpler to use gravity, friction and collision as the forces determining the hooking and activating mechanisms which were evolved.

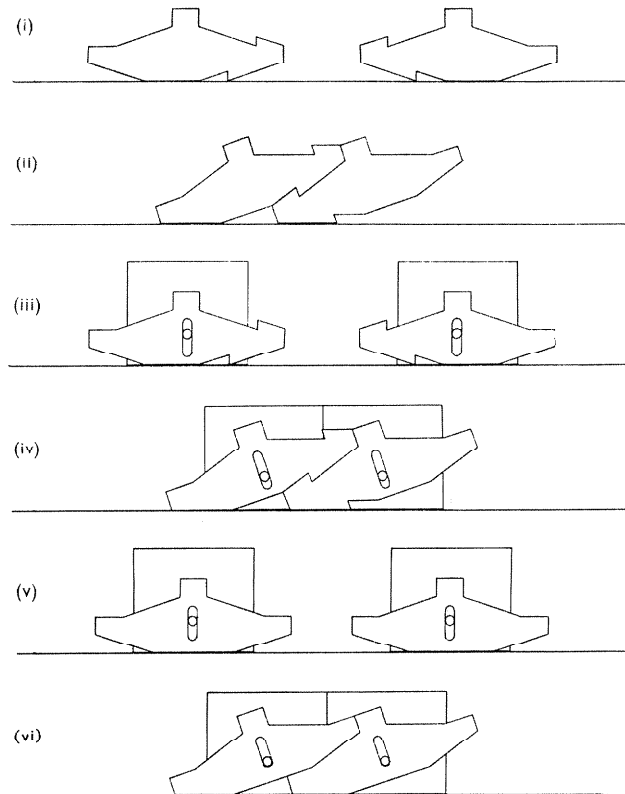

Fig. 2. The simplest units. (i) One shape of unit of this kind is sufficient. This is a scale drawing; height : length = 8 : 21. (ii) Basic activated structure or seed. (iii) Units with sliding cam lever mechanism. (iv) Activated structure with units shown in (iii). (v) Sliding cam activator elements in neutral position. These can transmit activation but they do not link. (vi) Close contact of elements shown in (v).

FIVE PRINCIPLES

Although this mechanical model, and those that are discussed later, may have very little direct relationship to self-reproduction in living organisms, it seems possible that certain principles, which emerged during their construction, may throw light upon this central biological problem. These principles do not, of course, have the status of mathematical theorems and it is conceivable that self-reproducing objects may exist which do not obey them.

The first principle is that the units must each have at least two possible states or phases. One of these can be called the neutral phase in which potential energy is lowest; this is the normal state of units when they are separate. Other states are associated with various degrees of activation. The close contact of two units is prerequisite for their junction or linkage and this can only take place when they are activated. Conversely, a unit can become activated by close contact with another activated unit. It follows from this principle that the material in its environment will not form self-reproducing structures when agitated unless it is activated in a special way by a seed. This is analogous to the denial of spontaneous generation. In the simplest actual models it may be difficult to ensure this; with more complex devices it is easier. There is no theoretical objection to the chance occurrence of other types of combinations of units which are not self-replicating. Indeed activated units are not all captured and built up

into structures; many are only temporarily activated by close contact and, because they do not become attached, they soon separate and fall back to their neutral states.

The second principle is that the activated structure or machine must have definite boundaries. It must have a defined beginning and an end, unlike a crystal, for example, which can be of any size. In the terminology of Schrödinger (1944), the live crystal must be 'aperiodic'. Thus an essential task in the construction of self-replicating machines is to prevent them from becoming attached to units of the wrong kind or to one another.

The third principle concerns energy. In order to form a self-reproducing structure, kinetic energy must be captured and held as potential energy. Each new replica, which is formed, will incorporate the same amount of energy in its structure as was in the original seed. The transformation of energy is mediated by a ratchet, a catch or equivalent mechanism, here called an 'active hook'. These hooks preserve the state of activation set up in the constituent parts of a structure. In the model shown in Fig. 1, and in all subsequently described devices, kinetic energy is supplied by horizontal agitation of the units. Among the various ways by which energy can be provided, in practice, the simplest is to place units upon a floor or plane surface which can be shaken horizontally; the energy of movement of the floor is conveyed to the units standing upon it by friction or by collision with walls at the boundaries of the surface.

The fourth principle concerns transference of activation and it can be expressed mechanically in a great variety of ways. Each activated unit must be capable of communicating its state to another unit with which it is in close contact. That is, an activated unit, whether or not it forms part of a complex, transmits its activation to its neighbour provided that it is close enough to do so. Usually only one unit at a time will be freshly activated but, if there is close packing, an unlimited number of adjacent units can be activated by a single starter, when adequate energy is supplied. In Fig. 1, activation and attachment are performed in one movement but the two processes are logically distinct and can be brought about by independent mechanisms. By having units with sliding parts as in Fig. 2 (ii) and (iii), the opportunities for transmission of activation from one unit to another, sometimes through intervening units, are enormously increased.

A fifth principle, which can be derived from the experiment shown in Fig. 1, concerns the track, or channel, to which the units are restricted. If there was another horizontal dimension in which these units could move, the chances of their becoming attached correctly in response to activation would be slight. The restriction imposed by a narrow track acts as a guide and facilitates the process of linking, so that the track itself is analogous to a catalyst. There is, however, another method of directing the units by restricting their movements and that is to supply them with interlocking edges as guides. By means of interdigitating shapes, units can be, as it were, encouraged to fit together in certain specified ways and prevented from coming into close contact in any other manner. An example of the kind of shapes of edges which can be used as guides is shown in Fig. 3. Here each element consists of a rectangular lamina, on which is superimposed another dentated lamina with the same surface area. The dentate shape tends to guide pieces to assemble in certain ways. The guides also cause what can be called 'passive hooking'. In Fig. 3, a_1 is passively hooked to a_2 by lateral guides. This property can be used, in association with the essential active latching, to build up extensive structures.

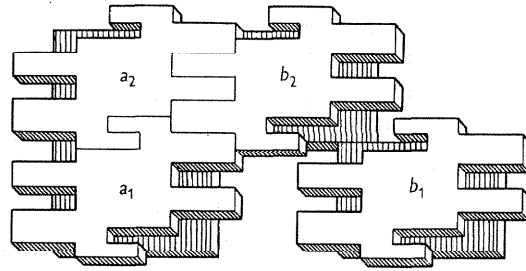

Fig. 3. Elements with interdigitating guides and lateral passive hooks which produce interlocking.

SIGNIFICANCE OF RELEASE MECHANISMS

By applying these five principles it is possible to construct machines of any desired degree of complexity which have the property of self-replication. Some useful new ideas which can be developed for this purpose concern release mechanisms. In order to build structures in which replication takes place by division into two parts at a suitable moment, as, for example, in living cells, release of previously attached units is essential. In one of its basic forms, the release of a bond between two units depends upon activation caused by close contact with a third unit. If this third unit should become attached to the very same unit, which it releases from its previous partner, an interesting phenomenon arises, which has some properties of a steady state. This is easily appreciated by examining Fig. 4.

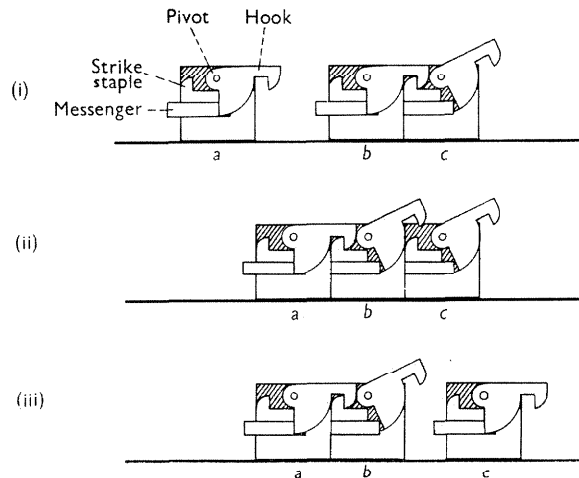

Fig. 4. Steady-state system of hook and release. (i) Separate element, *a*, and connected pair, *b* and *c*. (ii) Immediate effect of close contact of *a* with *b*. (iii) Ultimate effect; *a* and *b* remain attached as *b* and *c* were previously, while *c* is released and repelled.

Imagine a hook which pivots on an upright rectangular block on which also a staple, a peg, or strike plate, is available for the attachment of a similar hook belonging to another block. When two such blocks are in close contact so that one, *b*, is hooked to the other, *c*, it is so arranged that the hook of *c* is pushed into a release position. In the figure, this release is accomplished by a sliding part, or plunger, which acts as a 'messenger'. When two blocks are pushed together, they become linked but only two blocks can stay together. The bevels of the ends of the hooks enable

them to slide over the ridges of the staples without special activation. The mechanism can be extended so that release is not obtained until more than two pieces have been put together; that is to say, messenger parts can be designed to carry information through more than one unit.

The net result of adding a new piece to one of these groups of elements, like bc in Fig. 4 (i), is to preserve in a steady state the same configuration that was present before. The group absorbs a piece, a , at one end and rejects a piece, c , at the other end. A very important result is that the released part actually pushes itself away from the complex from which it has been detached. The energy used for this repulsion was stored up during the previous process of releasing. The detached part, as it pushes itself away, drops to its lowest energy state again, as the hook falls down to its previous neutral level.

In the design of self-replicating machines, effective use can be made of the steady-state mechanism of linkage and release by merely doubling it in a particular way. Each unit is supplied with two hooks and two strike staples, pointing in opposite directions. The result of adding a neutral unit to a complex of two such units is first to build up a triple group. Then a quadruple group is formed which breaks down into complexes each like the original one. The release mechanisms do not allow adjacent units to escape unless both hooks joining them together are simultaneously free. The whole process is shown in Fig. 5. The activated units b and c are doubly linked here while a and d are neutral and free. When a approaches the complex bc it becomes attached singly and breaks the upper bond joining bc . Addition of a fourth unit, d , to the triplet breaks the lower link between b and c . The two complexes ab and cd then repel one another while the previously released hooks sink to the lowest level, thereby reproducing two doubly-linked complexes exactly like the original one, bc .

COMPLETE REPRODUCTION WITH DIVISION OF THE SEED

In the incomplete systems described in Figs. 4 and 5, the first basic principle, that the structures only arise in response to the presence of a seed, is not obeyed. Two pieces can link without having to be activated in a special way. To make the system in Fig. 5 properly self-reproductive, an activating element would have to be put into each unit. This could be done by attaching to them slotted cams, like those shown in Fig. 2 (v). Two units, each supplied with one such mechanism, can only be in close contact if these cams are tilted, that is, activated, as shown in Fig. 2 (vi), and this activation is transmitted to any units which are picked up by a pre-arranged complex. In subsequent models, the mechanical ideas, used in Figs. 1 and 2 (i) and (ii) with solid units, are adapted to units with moving parts and the functions of hooking and activating are separated. A slotted cam device seems to work best for the activating element; and elements of this type are easily held on to the body of a unit.

In the system of reproduction shown in Fig. 1, the seed preserves its identity throughout the process. In Fig. 5, however, the mechanism sometimes involves destruction of the original seed when new replicas are formed. Owing to the symmetry of the triplet formation, abc , it is immaterial on which side of this complex the fourth unit, d , is added. According to whether d is added to c , as in Fig. 5, or added to a , the seed, bc , will or will not be broken down in the process of separation.

To distinguish between these two methods of reproduction a special apparatus is required. It could be called a counting or a rationing element and it involves a temporary 'memory'. In

Fig. 5, for example, the complex abc should, as it were, remember that it has last added a . Then it cannot accept another unit on the same side but can only go on building on the opposite side, by accepting d , as it does in Fig. 5 (iii). This remembering apparatus must be such that, after division into ab and cd , the new complexes immediately forget what has happened and start afresh ready to accept one new unit on each side. Several devices can be used for this purpose; one of them, drawn in Fig. 6 (i), uses a pendulum or suspended cam. The method is suitable when all units are of the same kind and similarly orientated as those in Fig. 5.

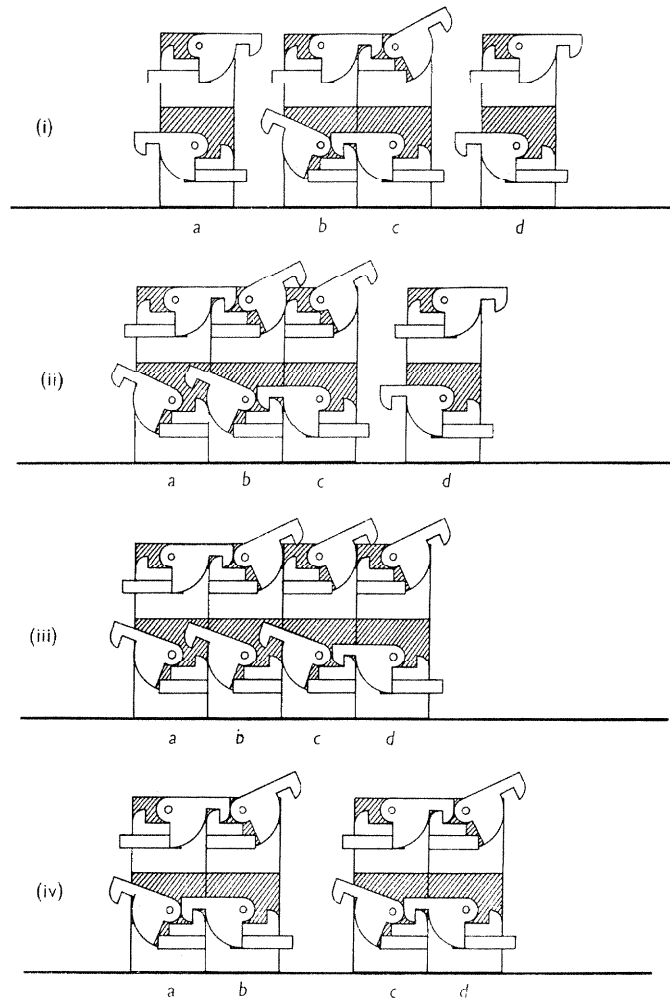

Fig. 5. Use of doubled hook and release mechanism as part of the self-replication process. (i) The activated units b and c are doubly linked: a and d are neutral and free. (ii) Unit a has become attached to bc . (iii) A fourth unit, d , is added and now b and c are unlinked. (iv) Separation of complexes ab and cd .

ARRANGEMENTS OF UNITS IN CHAINS

The question now arises as to how structures consisting of more than two units and still capable of precise replication can be built up. The natural method of extension is to connect structures in the form of a chain by lateral passive hooks, as foreshadowed in Fig. 3. Here there are two rows of pieces which interlock. When all are pushed together closely in a horizontal direction,

the two rows cannot be pulled apart laterally, that is, in the vertical direction in the figure. If the pieces in the rows were held together by some other hooking mechanism, which joined a_2 to b_2 and, eventually, a_1 to b_1 , the whole set of four would be firmly held together vertically by the passive lateral hooks. There is obviously no limit to the number of rows which can be assembled in such a way as this. One serious difficulty, however, arises in practice. There must be some method of ordering the assembling process. For example, in Fig. 3, if one row, a_2 and b_2 , were first assembled, part of the lower row, a_1 , could not be attached without separating them again. Some kind of orderly assembly is necessary if blocking is to be avoided. The problem of correct ordering can be solved by the construction of yet another device of the messenger-activator type.

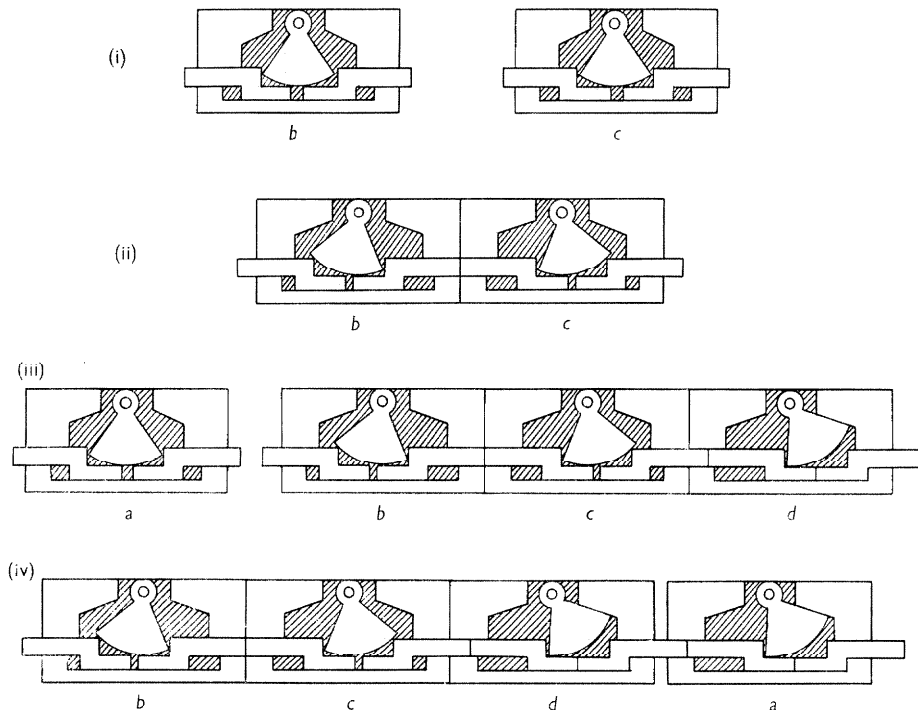

Fig. 6. Counting device using pendulum cam. (i) The elements b and c here show the neutral phase. The pendulum is in central position and the two plungers are free to move in either direction. Note that, if either plunger is pressed inwards, pressure on the other, in the opposite direction, will not push it out again. (ii) Elements b and c , when placed in close contact, settle down in the phases which balance one another. The pendulums are tipped in opposite directions and neither of the protruding plungers can be pressed inwards. (iii) Here an element d has been added in close apposition to c and it is forced to take up a new phase with pendulum and plungers pushed to the limits of their possible movements. If a is added to b on the other side, it will be forced into a similar limiting phase, the mirror image of the phase of d . (iv) If an attempt had been made to add a to d , as shown here, close apposition could not be achieved. The gap between a and d would prevent the linking of units of which these elements formed a part. After assembly of the group $abcd$ and division into two parts, ab and cd , these pairs of elements settle down to the balanced symmetrical phases which characterized bc in (ii).

A mechanism for determining the orderly assembly of units is pictured in Fig. 7 (i). It is three-dimensional and the principle, on which it works, is a sliding wedge. The wedges, which, in this design, are detachable, are situated one on either side of each unit. In their relaxed positions they cause obstruction and they prevent the first single unit from being assembled to

a seed consisting of a chain of units, anywhere except at one end. If the end position is already occupied, however, this fact enables the next place to be filled, for the wedges, belonging to units which are in contact laterally, are displaced upwards and inwards. In this position, the wedges do not obstruct the close contact of two units. Thus, in Fig. 7 (i), the four elements, x_1y_1 and x_2y_2 , are supposed to form part of a seed consisting of four units arranged in a chain, two rows

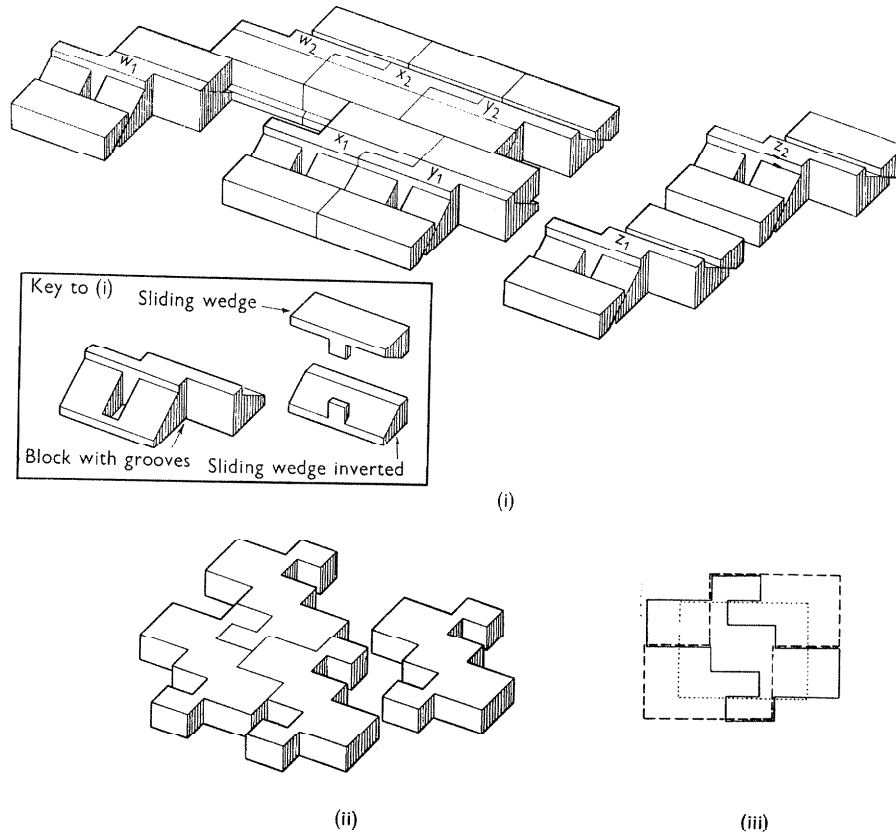

Fig. 7. Device for controlling order of assembly along a chain. (i) Detail of mechanism for determining assembly order of units. The detachable parts of the mechanism are shown separately in the key to the figure. When two units which contain elements of this kind are in close lateral apposition, the sliding wedges are pushed upwards and they cease to act as obstructions. Thus z_1 can only be aligned close to y_1 , not to y_2 , but, because w_2 is already in position against x_2 , w_1 can come in close to x_1 . (ii) Bases with interdigitating guides and lateral passive hooks for combination with the elements shown in (i). (iii) Plan showing the superimposition of mechanism (i), - - -, on base (ii), —, showing also the site of rectangle, ..., on which the superstructure of hooks and activators would rest.

long. A new unit, z_1 or z_2 , cannot be added to y_2 but can be added to y_1 . After z_1 has been assembled, the unit z_2 can be added to y_2 and this process, in reverse order, is shown in the assembly first of w_2 and then of w_1 . The mechanism shown in Fig. 7 (i) can have guides and lateral hooks attached, similar to those in Fig. 3, all of which are built into the unit by superimposition. Fig. 7 (ii) shows a suitable complementary configuration of guides and hooks for use with the mechanism shown in Fig. 7 (i). The plan for alignment of these parts with the rest of the functional unit is shown in Fig. 7 (iii).

DESIGN OF A UNIT FOR A SELF-REPLICATING CHAIN

The construction of a unit, which can act as neutral 'food' for a fully automatic self-reproducing structure of any required length, can now be described. The functional elements needed in each unit are listed here:

- (1) Two active hooks and two strike staples facing in opposite senses (Fig. 5).
- (2) Releasing messengers (Fig. 5).
- (3) One or more activating levers (like the slotted cams shown in Fig. 2 (v)).
- (4) A counting device (Fig. 6), pendulum and messengers.
- (5) An assembly order controller (Fig. 7 (i)), sliding wedges.
- (6) A set of guides and lateral hooks (Fig. 7 (ii)).

Elements of the first four kinds can be placed side by side upon a rectangular platform, and together they then form the superstructure of the unit. Elements (5) and (6) can be used as the base, superimposed upon one another as shown in Fig. 7 (iii), and lying below the rectangular platform. A compact arrangement of all these elements makes the kind of unit which is described by the drawing in Fig. 8.

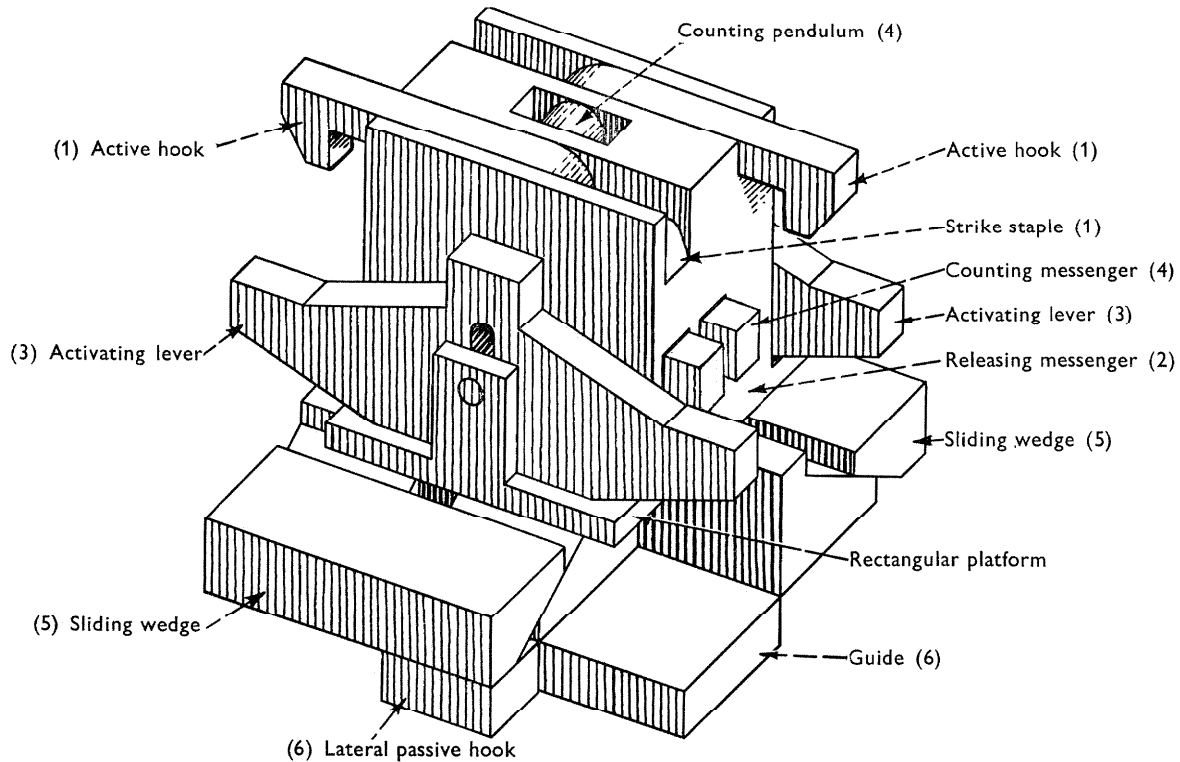

Fig. 8. Complete *S*-unit for a self-replicating chain.

The manner in which seeds in the form of chains can grow and divide by assimilating such units is demonstrated in Fig. 9. It is immaterial how many rows of activated units form the original group. Whatever number is chosen will be repeated in the descendants, and so long as there are enough fresh units in neutral condition available for food, and enough energy of agitation, the process will continue.

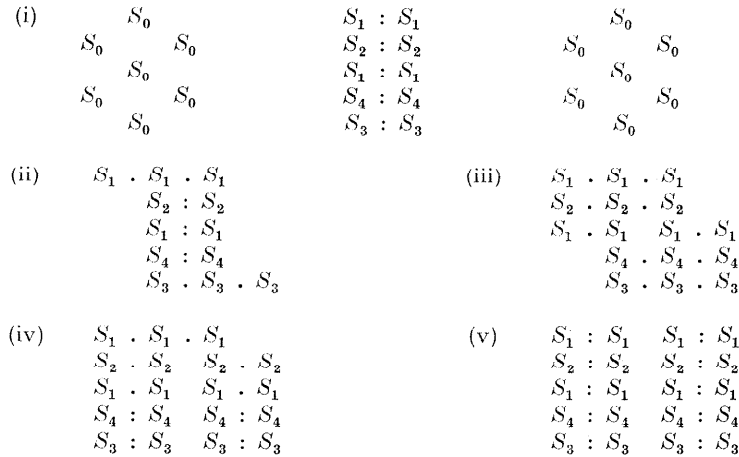

Fig. 9. Representation of the self-reproduction of a chain structure composed of S -units. (i) The self-reproducing chain structure or seed, consisting of five pairs of units attached laterally, is viewed, as it were, from above. Many units in neutral state are shown in the environment. Attachment of neutral units to the seed is only possible at the top left and bottom right-hand corners. The colon ($:$) indicates double linkage of active hooks. (ii) Assimilation and programmed activation of neutral material has begun at both ends. Single linkage of an active hook is indicated by a point (\cdot). (iii) Building proceeds in an orderly manner. As soon as a row of four units has been completed, separation begins. This occurs first near the centre of the chain. (iv) Separation cannot be complete until the last unit has been put in place. Separation has already begun at the bottom end, here, and the newly formed chains are repelling one another and settling down to the doubly-linked state. (v) Finally, two new chains separate and the hooks all take their lowest energy levels, as was shown in Fig. 5 (iv).

In the present design, each unit is cyclically symmetrical, that is to say, it is unchanged by rotation through 180° round a vertical axis. This symmetry facilitates the replication process in practice. However, when a unit is activated, asymmetry can be introduced because each slotted cam lever can take up more than one position, that is, it can be programmed in two ways. If there are two such levers on each unit, as in Fig. 8, each row in the seed can have four possible configurations according to the way in which its activating levers are tilted. Thus, calling the neutral unit S_0 , there can be,

$$S_0, \text{---}; \quad S_1, //; \quad S_2, / \backslash; \quad S_3, \backslash \backslash; \quad \text{and} \quad S_4, \backslash /.$$

The effect is to make it possible for a self-reproducing machine of this kind to have an unlimited number of different alternative patterns. The model unit S_0 , in Fig. 8, is given in its crudest form so that each function is separately demonstrable in one kind of unit. Units almost exactly like S_0 have been satisfactorily constructed and demonstrated, but the design can be simplified. For example, functions 1, 2 and 3 could be combined in one element and so also, to some extent, could functions 4 and 5. Moreover, if the units need not all be of the same design, there can be some distribution of functions among them. When there is an efficient ordering mechanism, the counting device is only required in units which lie at the beginning and end of a chain.

UNLIMITED CHAIN BUILT FROM TWO KINDS OF UNITS

A quite feasible refinement of this model, which may have some biological significance, is introduced by breaking down the structure of each symmetrical unit, S_0 , into two interdigitating subunits. These can be made with connecting links of a non-releasing type, like those shown in

Fig. 2 (iii) and (iv). The arrangement is economical because separate activating elements are not then required: these are incorporated in the non-releasing hook mechanism. Each row of the chain structure will consist of four subunits replacing two symmetrical units. The subunits can be designed to be complementary or identical. In either case some revision of mechanical detail is necessary and there are many alternative designs possible. One method is to change the releasing messenger system so that unlocking only occurs when four subunits are in serial close contact. The counting device has to be of a type which allows just two subunits to be added in each row on either side of the seed. A detailed description of this machine would require considerable space but no new principles are used in its construction.

The way in which the refined machine grows and divides can be described by using the notation $S = A/B$ for the association of two complementary subunits A and B by means of a non-releasing link. The method of replication for one row can be summarized thus:

$$A + B + (A/B : A/B) + A + B \text{ leads to } A + (B \cdot A/B : A/B \cdot A) + B, \text{ then to} \\ (A/B \cdot A/B \cdot A/B \cdot A) + B \text{ and, finally, to } (A/B : A/B) + (A/B : A/B).$$

The sign, $+$, here, means that the two objects it joins are near to one another but not in close contact; a single point, \cdot , indicates a single active link; and a colon, $:$, a double active link.

Since every S -unit has been divided here into two subunits, each of these need carry only one lateral passive hook and one sliding wedge. As before, a long chain can be used as seed and neutral subunits will become attached to it on each side, one by one in a regular sequence. The system of replication of such a chain is shown in Fig. 10. Here, the neutral material is supposed to consist of two complementary types of subunit, A_0 and B_0 , capable of interdigitation. Moreover, each subunit has at least two ways of being activated, so that a combined pair can have at least two forms, A_1/B_1 or A_2/B_2 . Thus a varied structure of any desired length can be built.

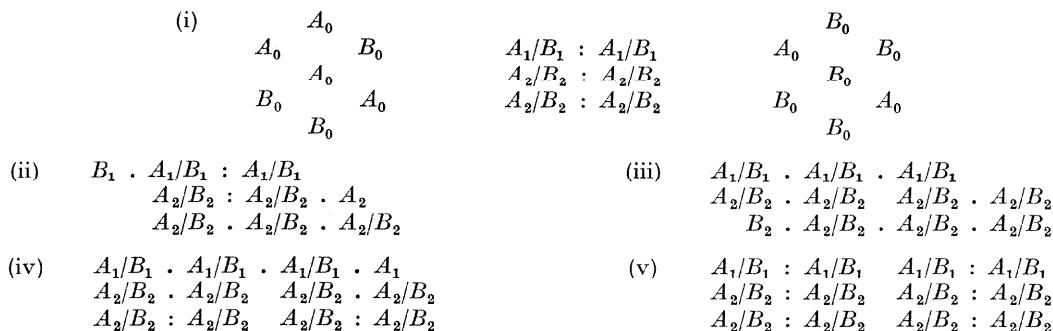

Fig. 10. Self-replicating chain structure built from units of two kinds. (i) Chain structure surrounded by neutral units of two complementary kinds. (ii) Beginning of self-replication. (iii) Advanced stage; separation starting near the centre. (iv) Final stage; one more unit required. (v) Completed replication.

By means of these chain structures, units of one or two different kinds can be taken up and built into new, exactly similar, chains. Since each section can have two or more different forms of activation, if there are N sections there are at least 2^N different possible complexes which can reproduce themselves precisely, or, as some people would say, 2^N different programmes.

POSSIBLE RELATIONSHIP TO THE LIVING CELL NUCLEUS

It is noteworthy that, by following the original plan to solve von Neumann's problem, a machine has been constructed which has certain similarities to deoxyribose nucleic acid, the basic genetical substance. DNA occurs in the form of strands, made up out of sections whose specific structure determines the programme carried by the strand. At the present time, however, the orthodox view is that, during replication, each strand first cracks down its centre and that, as it does so, it builds up new complete strands. This idea, if compared with the present model, would require breaking each *S*-unit into two subunits at every replication. It is very difficult to devise any automatic mechanism which could function in this way. In the working models, so far successfully made, there is no breaking down of units in the process of reproduction. The separation of like groups occurs but never of unlike groups. This may be a defect in the design of macroscopic automata, which may not be analogous to molecules.

It is, nevertheless, worth while considering whether the artificial processes, described in Figs. 9 and 10, can throw any light on the actual method of replication employed by DNA. For the moment it could be assumed not unreasonably that the live DNA molecular chain does in fact consist of two similar strands lying side by side. Each of these strands would correspond to a string of *S*-units properly activated for reproduction. Pursuing the analogy, an *S* unit, which need not be symmetrical, would correspond to one pair of interlocked nucleotides in the Watson & Crick (1953*a, b*) and Wilkins (1957) arrangement.

According to the ideas in the present paper, the hydrogen bonds and molecular interdigitations of purines and pyrimidines, which hold complementary nucleotides together in the living organism, once they have been formed are not separated again. The replication system used by the machine would perhaps agree with that indicated by Bloch (1955) and discussed by Delbruck & Stent (1957). The purine-pyrimidine bonds would correspond to hooks of the type shown in Figs. 1 and 2 and used in Fig. 10 to hold the subunits *A* and *B* together. The main work of hooking and releasing, which is performed by mechanisms of the type shown in Figs. 4 and 5, would, in DNA, be done by part of the orthophosphoric acid not already occupied in lateral attachments. The special reason for attributing the function of releasable hooking to phosphate bonds is that, in this type of link, energy can be stored. There is a comparable storage of energy in the endothermic reaction, involving the formation of pyrophosphate. The other necessary mechanisms, concerned with counting and ordering, would have to be allocated to other parts of the nucleotide molecule. They may be functions of the pentose sugars. Ribose in RNA may determine a type of reproduction without division of the seed and different from that used by DNA. Further speculation on these lines at the present moment would appear unprofitable.

SUMMARY

The construction of various types of machines which can be automatically self-reproducing, in a sense derived from von Neumann, has been outlined. The features, which any such machine must possess, have been discussed and their possible significance in the understanding of DNA replication has been indicated.

I am much indebted to Dr C. A. B. Smith for his valuable suggestions in the interest of making this paper comprehensible, and to Mr A. J. Lee for his admirable drawings.

REFERENCES

- BLOCH, D. P. (1955). A possible mechanism for the replication of the helical structure of deoxyribonucleic acid. *Proc. Nat. Acad. Sci., Wash.*, **41**, 1058.
- DELBRUCK, M. & STENT, G. S. (1957). On the mechanism of DNA replication. *The Chemical Basis of Heredity*, p. 699. Baltimore: The Johns Hopkins Press.
- HALDANE, J. B. S. (1954). The origin of life. *New Biol.* **16**, 12.
- VON NEUMANN, J. (1951). *Cerebral Mechanisms in Behaviour*. New York and London: McGraw-Hill.
- PENROSE, L. S. & PENROSE, R. (1957). A self-reproducing analogue. *Nature, Lond.*, **179**, 1183.
- SCHRÖDINGER, E. (1944). *What is Life?* Cambridge University Press.
- TURING, A. M. (1937). Computability and λ -definability. *J. Symb. Logic*, **2**, 153.
- WATSON, J. D. & CRICK, F. H. C. (1953*a*). Molecular structure of nucleic acids. A structure for deoxyribonucleic acid. *Nature, Lond.*, **171**, 737.
- WATSON, J. D. & CRICK, F. H. C. (1953*b*). Genetical implications of the structure of deoxyribonucleic acid. *Nature, Lond.*, **171**, 964.
- WILKINS, M. H. F. (1957). Molecular structure of deoxyribose nucleic acid and nucleoprotein and possible implications in protein synthesis. *Biochem. Soc. Symp.* **14**, 13.